

DISCOVERY 10



DESCRIZIONE

Robot industriale a 6 assi di lavoro.
Portata al polso 10 kg.
Possibilità di collegamento assi esterni.
Interfacciamento con qualsiasi modello di saldatrici.



DESCRIPTION

Industrial robot with 6 working axes.
10 kg on the wrist.
Possibility of connecting external axes.
Interfacing with any model of welding machines.



BESCHREIBUNG

Industrieroboter mit 6 Achsen.
Getragen am Handgelenk 10 kg.
Möglichkeit der Verbindung externer Achsen.
Schnittstelle mit jedem Modell von Schweißmaschinen.



DESCRIPTION

Robot industriel à 6 axes de travail.
Portée au poignet 10 kg.
Possibilité de connexion des axes externes.
Interface avec tous les modèles de machines à souder.



DESCRIPCIÓN

Robot industrial de 6 ejes de trabajo.
Carga en la muñeca 10 kg.
Posibilidad de conexión de ejes externos.
Interfaz con cualquier modelo de máquinas de soldadura.

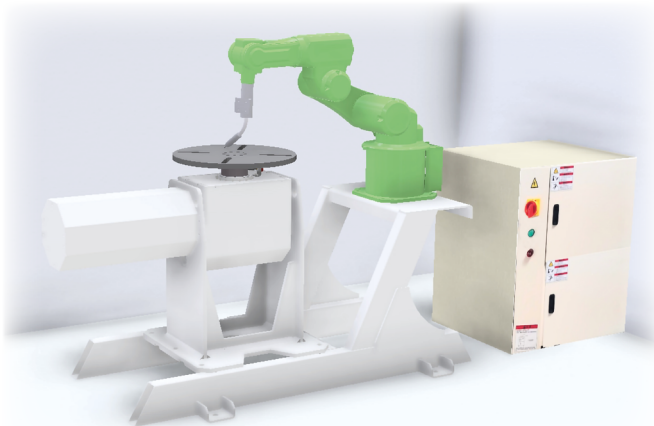
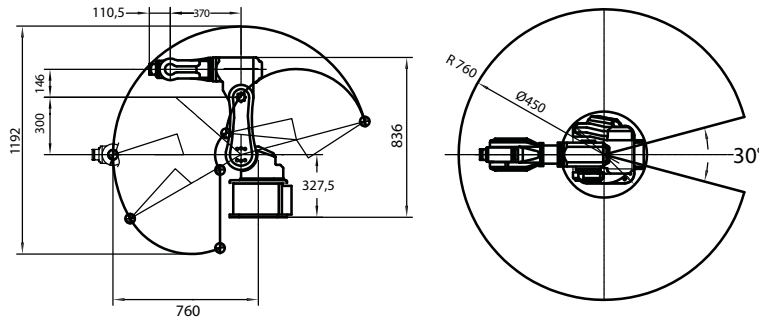

Payload	10 kg	
Reach	750 mm	
N° axes	6	
Repeatability	± 0,05 mm	
Max. motion range	Axis 1	± 165°
	Axis 2	+135°/-70°
	Axis 3	+85°/-85°
	Axis 4	± 150°
	Axis 5	+30°/-240°
	Axis 6	± 360°
Max. speed	Axis 1	148°/sec
	Axis 2	148°/sec
	Axis 3	222°/sec
	Axis 4	222°/sec
	Axis 5	222°/sec
	Axis 6	360°/sec
Weight	~85 kg	
Mounting type	Ground, bracket, ceiling	
Ambient temperature	5°C ~ 45°C	