





# DISCOVERY 5

 **DESCRIZIONE**  
 Robot industriale a 6 assi di lavoro.  
 Portata al polso 5 kg.  
 Possibilità di collegamento assi esterni.  
 Interfacciamento con qualsiasi modello di saldatrici.

 **DESCRIPTION**  
 Industrial robot with 6 working axes.  
 5 kg on the wrist.  
 Possibility of connecting external axes.  
 Interfacing with any model of welding machines.

 **BESCHREIBUNG**  
 Industrieroboter mit 6 Achsen.  
 Getragen am Handgelenk 5 kg.  
 Möglichkeit der Verbindung externer Achsen.  
 Schnittstelle mit jedem Modell von Schweißmaschinen.

 **DESCRIPTION**  
 Robot industriel à 6 axes de travail.  
 Portée au poignet 5 kg.  
 Possibilité de connexion des axes externes.  
 Interface avec tous les modèles de machines à souder.

 **DESCRIPCIÓN**  
 Robot industrial de 6 ejes de trabajo.  
 Carga en la muñeca 5 kg.  
 Posibilidad de conexión de ejes externos.  
 Interfaz con cualquier modelo de máquinas de soldadura.

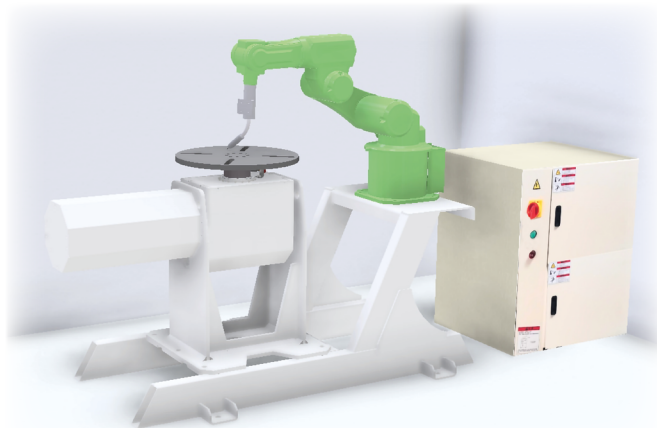
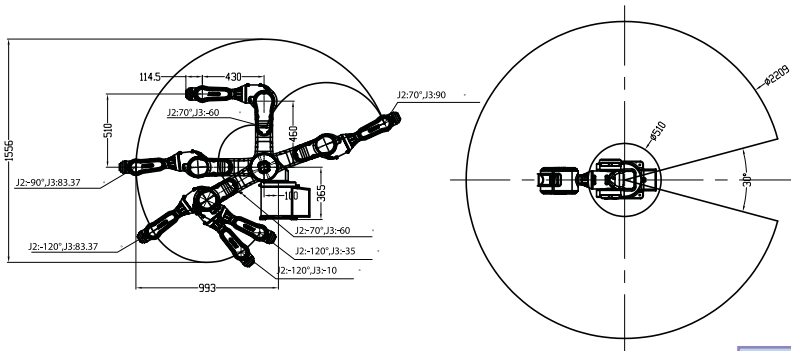

Payload	5 kg	
Reach	990 mm	
N° axes	6	
Repeatability	± 0,03 mm	
Max. motion range	Axis 1	± 165°
	Axis 2	+120°/-75°
	Axis 3	+85°/-100°
	Axis 4	± 185°
	Axis 5	+30°/-230°
	Axis 6	± 360°
Max. speed	Axis 1	225°/sec
	Axis 2	225°/sec
	Axis 3	225°/sec
	Axis 4	225°/sec
	Axis 5	225°/sec
	Axis 6	225°/sec
Weight	~55 kg	
Mounting type	Ground, bracket, ceiling	
Ambient temperature	5°C ~ 45°C	