

POWER 76 PLC



DESCRIZIONE

Portata massima 100 kg.
Inclinazione manuale.
Ciclo automatico con sormonto regolabile e innesco saldatrice, ritardo partenza tavola, crater filler e schermatura HF.



DESCRIPTION

Maximum load 100 kg.
Manual tilt.
Automatic cycle with adjustable over-weld, welding power source start, delayed table start, crater filler and HF shielding.



BESCHREIBUNG

Manuelle Neigung.
Maximale Belastung 100 kg.
Automatischen Zyklus mit einstellbarer ueberlappung, Schweißstromquelle starten, verzögerter Tischstart, Kraterfüller und HF-Abschirmung.



DESCRIPTION

Portée 100 kg.
Inclinaison manuelle.
Cycle automatique avec recouvrement réglable, commande simultanée du poste retard au démarrage, evanouissement d'arc et protection HF.



DESCRIPCIÓN

Capacidad máxima 100 kg.
Inclinación manual.
Ciclo automático con solape regulable, circuito cebado soldadura, retardo arranque mesa, relleno de cráter, protección alta frecuencia.

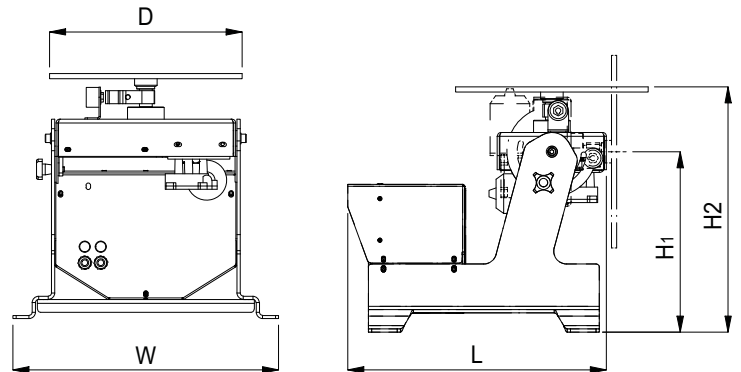
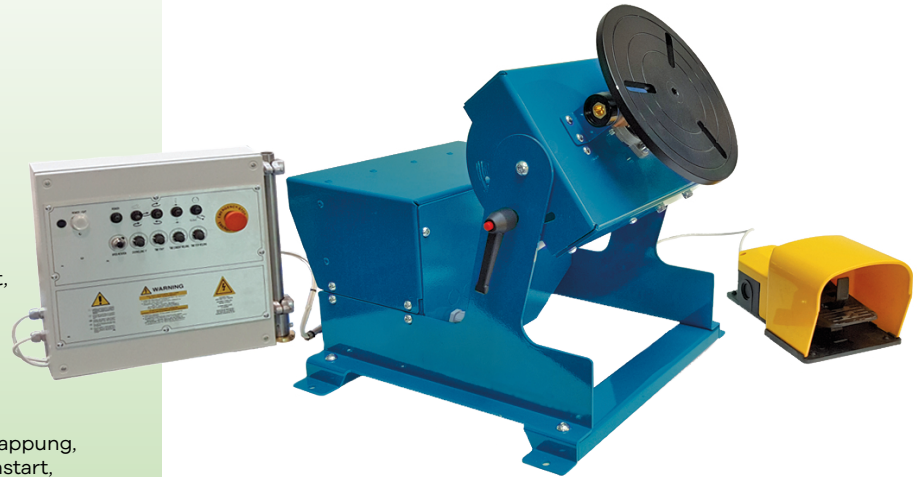

MF POWER 76 PLC

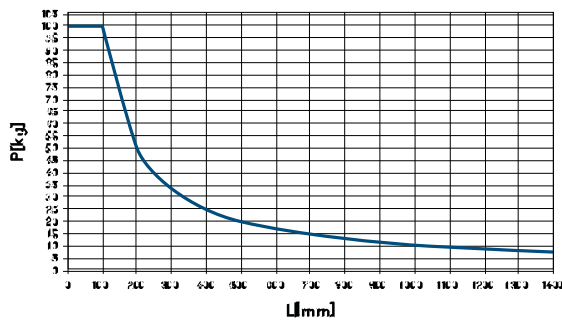

MT POWER 76 PLC

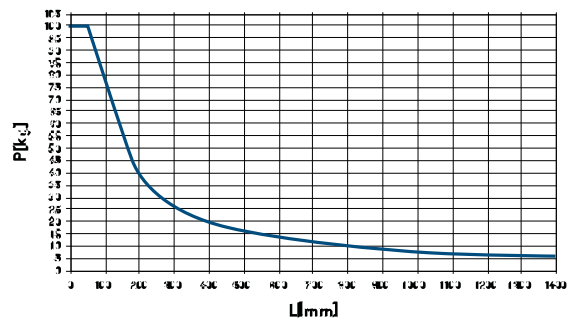

| Tipo motore | L mm | W mm | H1 mm | H2 mm | D mm | volt | rpm | Portata / Load / Portee / Tragkraft / Capacidad | | kg |
|-------------|------|------|-------|-------|------|------|-------|---|-------------|----|
| | | | | | | | | Horizontal kg | Vertical kg | |
| DC | 450 | 414 | 281 | 378 | 300 | 220 | 0,6-6 | 100 | 50 | 26 |