

SPS 150S HC PLC



DESCRIZIONE

Portata massima 150 kg.
Inclinazione manuale.
Ciclo automatico con sormonto regolabile e innesco saldatrice, ritardo partenza tavola, crater filler e schermatura HF.
Rotazione con motore in corrente alternata, con inverter.



DESCRIPTION

Maximum load 150 kg.
Manual tilt.
Automatic cycle with adjustable over-weld, welding power source start, delayed table start, crater filler and HF shielding.
Slewing by AC motor with inverter.



BESCHREIBUNG

Maximale Tragfähigkeit 150 kg.
Kippung manuell.
Automatischen Zyklus mit einstellbarer ueberlappung, Schweißstromquelle starten, verzögerter Tischstart, Kraterfüller und HF-Abschirmung.
Schwenken durch Wechselstrommotor mit Wechselrichter.



DESCRIPTION

Portée 150 kg.
Inclinaison manuelle.
Cycle automatique avec recouvrement réglable, commande simultanée du poste retard au démarrage, évanouissement d'arc et protection HF.
Rotation avec moteur à courante alternée avec inverter.



DESCRIPCIÓN

Capacidad máxima 150 kg.
Inclinación manual.
Ciclo automático con solape regulable, circuito cebado soldadura, retardo arranque mesa, relleno de cráter, protección alta frecuencia.
Rotación por motor de corriente alterna con inverter.

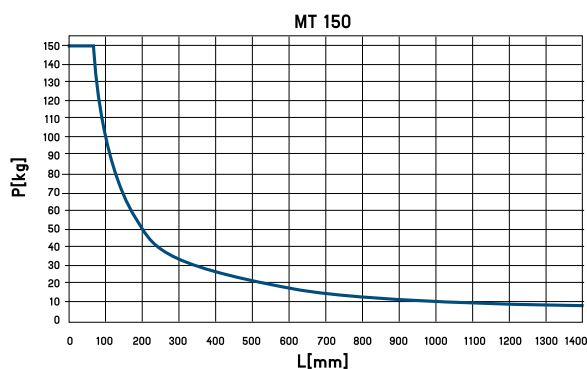
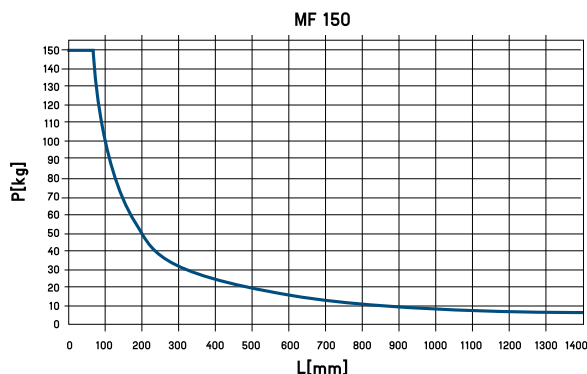
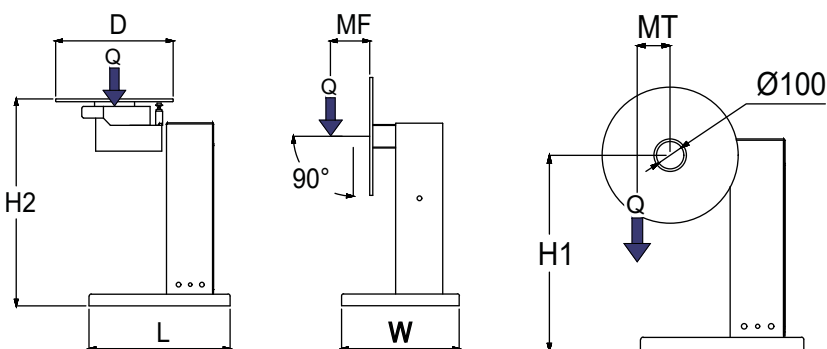

Tipo motore	Q kg	MT danm	MF danm	D mm	H1 mm	H2 mm	L mm	W mm	rpm	volt	volt	volt	kg
AC	150	10	10	500	730	910	700	700	0,9-9	1x220	24	220	132