

SPS POWER 120 I PLC

DESCRIZIONE
 Portata massima 120 kg.
 Inclinazione manuale.
 Ciclo automatico con sormonto regolabile e innesco saldatrice, ritardo partenza tavola, crater filler e schermatura HF.
 Rotazione con motore in corrente alternata, con inverter.

DESCRIPTION
 Maximum load 120 kg.
 Manual tilt.
 Automatic cycle with adjustable over-weld, welding power source start, delayed table start, crater filler and HF shielding.
 Slewing by AC motor with inverter.

BESCHREIBUNG
 Maximale Tragfähigkeit 120 kg.
 Kippung manuell.
 Automatischen Zyklus mit einstellbarer ueberlappung, Schweißstromquelle starten, verzögerter Tischstart, Kraterfüller und HF-Abschirmung.
 Schwenken durch Wechselstrommotor mit Wechselrichter.

DESCRIPTION
 Portée 120 kg.
 Inclinasion manuelle.
 Cycle automatique avec recouvrement réglable, commande simultanée du poste retard au démarrage, evanouissement d'arc et protection HF.
 Rotation avec moteur à courante alternée avec inverter.

DESCRIPCIÓN
 Capacidad maxima 120 kg.
 Inclinación manual.
 Ciclo automático con solape regulable, circuito cebado soldadura, retardo arranque mesa, relleno de cráter, protección alta frecuencia.
 Rotación por motor de corriente alterna con inverter.

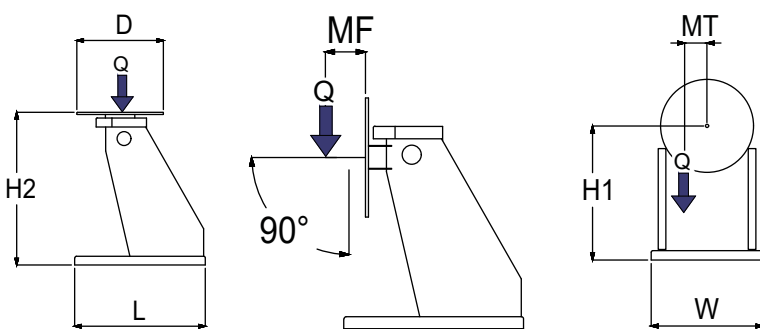
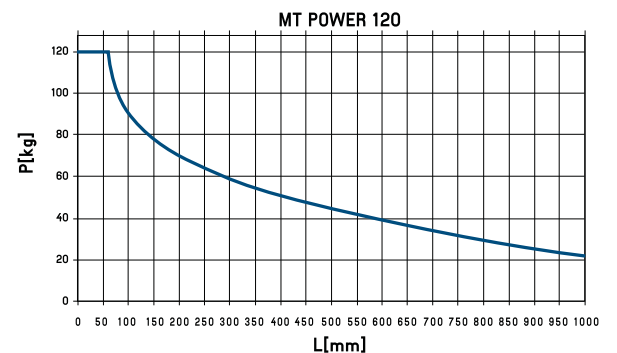
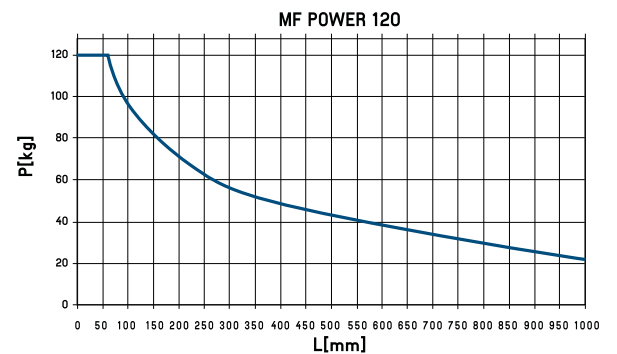

Tipo motore	L mm	W mm	H1 mm	H2 mm	D mm	volt	rpm	Portata / Load / Portee / Tragkraft / Capacidad		kg
								Horizontal kg	Vertical kg	
AC	750	523	600	800	400	230	0,6-6	120	60	60