

ZEPHYR 3

ZEPHYR 3



DESCRIZIONE
Robot collaborativo a 6 assi.
Portata al polso 3 kg.
Interfacciamento con posizionatori modello "AVALON" e qualsiasi saldatrice.



DESCRIPTION
6 axis collaborative robot.
3 kg on the wrist.
Interfacing with positioning devices "AVALON" model and any welding machine.



BESCHREIBUNG
Kollaborativer Roboter mit 6 Achsen.
Getragen am Handgelenk 3 kg.
Schnittstelle zu den Stellwerken Modell "AVALON" und jede Schweißmaschine.



DESCRIPTION
Robot collaboratif à 6 axes.
Portée au poignet 3 kg.
Interface avec les positionneurs modèle "AVALON" et toute machine à souder.



DESCRIPCIÓN
Robot colaborativo de 6 ejes.
Carga en la muñeca 3 kg.
Interconexión con los posicionadores modelo "AVALON" y cualquier máquina de soldadura.

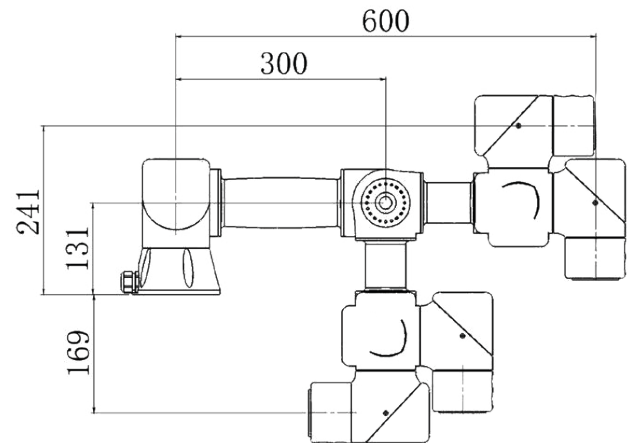

Payload	3 kg	
Reach	600 mm	
N° axes	6	
Repeatability	± 0,03 mm	
Max. motion range	Axis 1	± 180°
	Axis 2	± 180°
	Axis 3	± 180°
	Axis 4	± 180°
	Axis 5	± 180°
	Axis 6	± 360°
Max. speed	Axis 1	180°/sec
	Axis 2	180°/sec
	Axis 3	180°/sec
	Axis 4	180°/sec
	Axis 5	180°/sec
	Axis 6	180°/sec
Weight	~17 kg	
Mounting type	Ground, bracket, ceiling	
Ambient temperature	5°C ~ 45°C	
Main parameters	40 channel I/O interface, 4-channel analog interface, EtherCAT communication	

